

Aqueous Rotary Drum

LEAN



DRUM

Right Priced
Right Sized
Cleaning Tool

- Wash and Blow-off In One Small Package
- Engineered for Lean/Cellular Manufacturing
- 4 CU Feet per Hour Production
- Energy Efficient Design
- Single Point Utility Connection
- Easy Maintenance Design



RANSOHOFF

Providing Tomorrow's Cleaning Technology Today

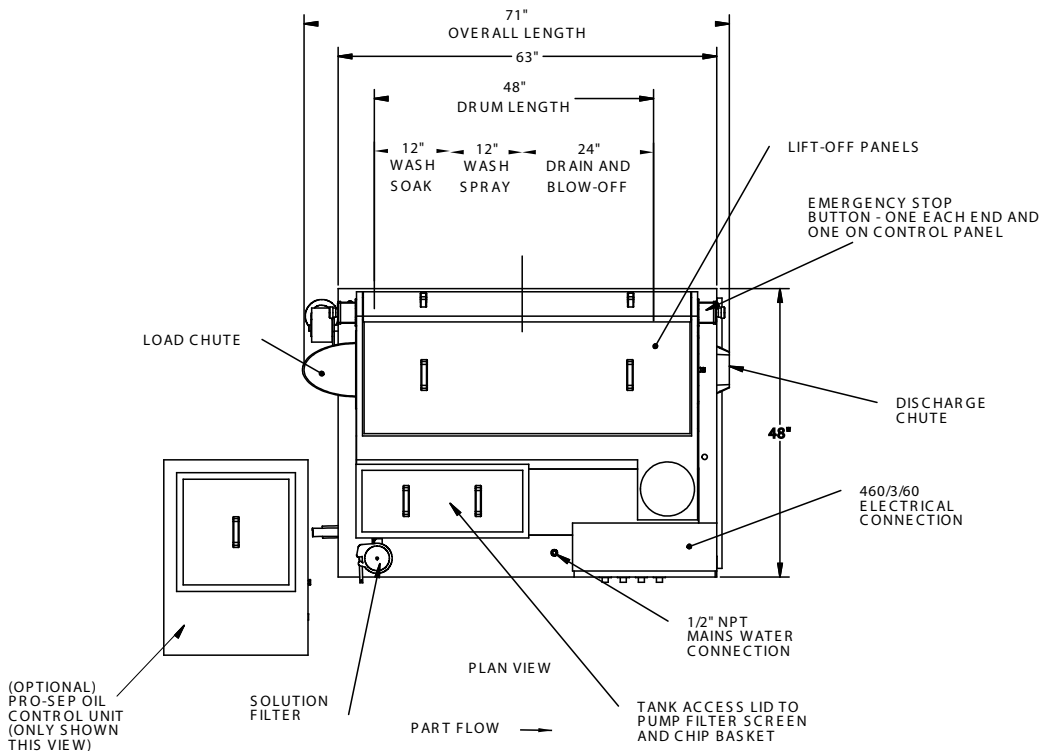

Standard Features

- Full-Flow Solution Filtration
- Low Profile Design
- Maximum 85 dB (A) Noise Level
- Non-recirculating Pressure Blower
- Electrically Heated Solution Tank
- Fully Insulated Solution Tank
- Sliding Housing Doors
- Variable Speed Drum Drive
- Automatic Water Make-up System
- Pressure Gauge at Filter
- Stainless Steel Construction
- Single Point Utility Connections
- Marine Door for Easy Clean-out
- Machine Drain Pan
- Epoxy Paint
- Forklift Access Location in Base
- Standard Relay Logic Controls
- Energy Savings Construction
- 304 Stainless Steel Construction
- Nema 4 Control Panel
- Easy Maintenance Design

Optional Features

- Exhaust Fan Demister
- Additional Process Stages
- Rinse/Rust Inhibit
- Pro-Sep Oil Removal
- Full-Flow Chip Basket
- Drain Valves
- PLC Controls
- Premier Finish with Satin Black/ Polished Stainless Steel Bottom

Machine Specifications: Base Machine - Wash and Blow-Off

Model Number	LD-15
Part Production	4 CU FT./Hour-3" Max. Part Size
Paint (Top/Bottom)	Platinum/Oyster Gray
Floor Space	5' 4" H x 4' W x 6' L
Wash Pump Capacity	30 GPM @ 25 PSI
Blow-Off Fan Capacity	550 CFM @ 6" S.P.
Tank & Housing Construction	11GA -- Type 304 Stainless Steel
Drum Construction	14GA -- Type 304 Stainless Steel 2" Helix and 6" Pitch
Wash Tank Capacity	75 Gal.
Wash Heat	Electrical -- 9 KW Approximately 130° F
Blow-Off Heat	Electrical -- 10 KW Approximately 180° F
Utility Requirements-Electricity	48 KW @ 460 Volts 60 Ampere Service

Machine Specifications are Subject to Change Without Notice

**Right Price
Right Sized
Cleaning Tool**



Ransohoff, Inc. Blackstone-NEY Ultrasonics Ransohoff, plc.
Ransohoff Specialty Chemicals Group Ransohoff Environmental Systems Group



A Cleaning Technologies Group Company

United States Operations:

Ransohoff, Inc.

4933 Provident Drive | Cincinnati, Ohio 45246

Tel: (513)-870-0100 | (800) 248-WASH | Fax: (513) 870-0105

EMAIL: info@ransohoff.com | www.ransohoff.com